



Küba SG commercial





Küba SG commercial: Specific advantages

High performance air cooler for commercial applications with a large scope and complete capacity spectrum.

Draw-through fans guide the air flow evenly through the heat exchanger, enabling the maximum use of the air cooler surface.

Q_0 0,7 — 32 kW

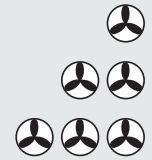

Goods are cooled down more quickly with optimum air distribution, thanks to the patented, standard air straightener.

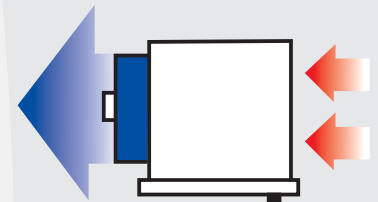

The Küba SG commercial can cope with the most difficult environmental demands due to its comprehensive standard equipment and numerous alternative versions as well as accessories.

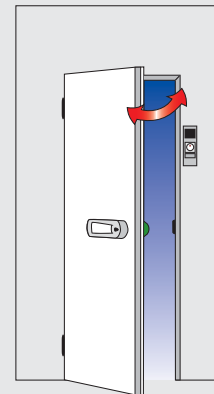

Precision in the cold storage room has a name: Küba SG commercial

The Küba SG commercial sets the worldwide standard for all high performance Air Coolers in cold and frozen Chill Rooms.

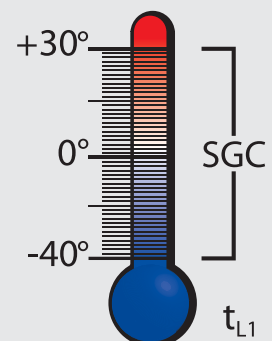



Küba SG commercial: Specific advantages

What are the effects of a long air throw range?

Grille

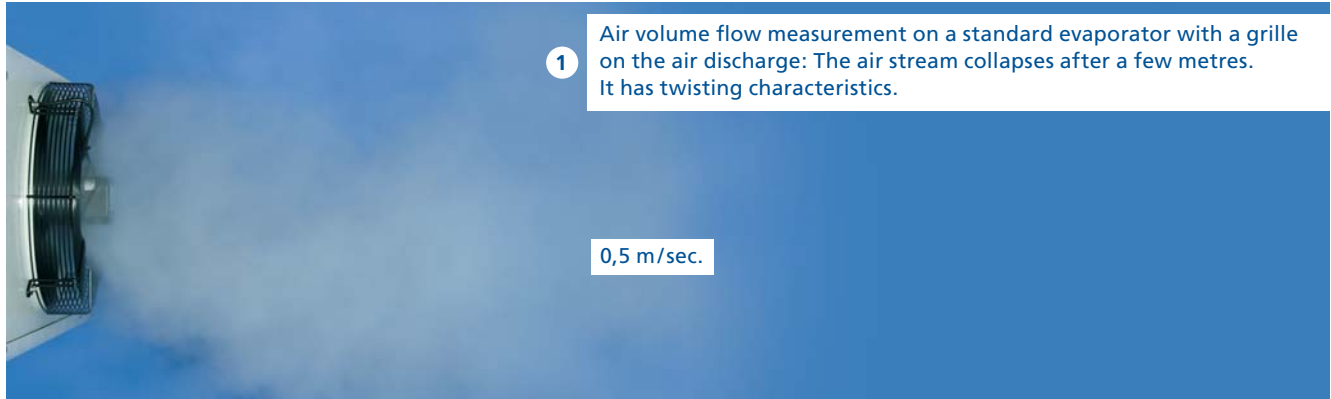

Grille and guide-wheel

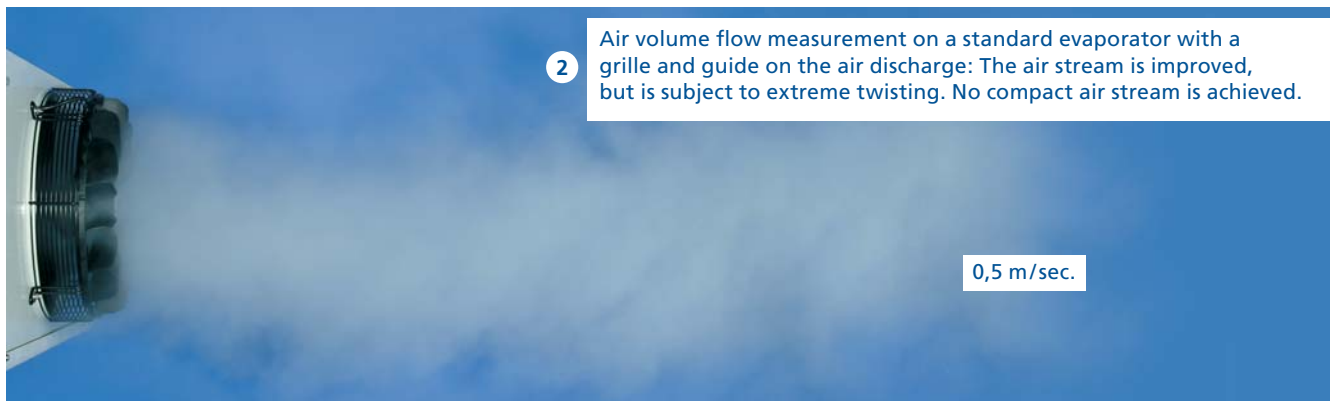

Küba air straightener

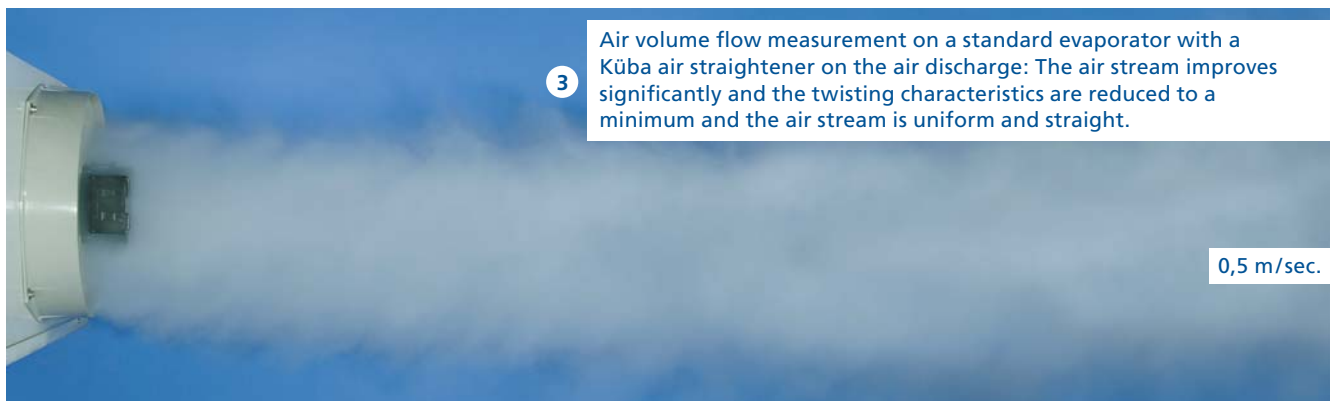

Air throw comparison at a nominal capacity of 5.95 kW





Küba SG commercial: Specific advantages

Goods stay at a uniform temperature due to improved air distribution

Refrigeration in large, long cold storage areas can be effected with Küba Air Coolers. Very long throw ranges can be achieved with the air straighteners. This allows the chilled air to reach the most remote corners of the cold storage area. In connection with the product specific stacking, room ventilation is trouble-free. Heat pockets are prevented.

Clear advantages are:

- Even air distribution
- Short cooling times
- Uniform product cooling
- No fluctuations in product temperatures
- Quality is retained

Küba Air Straighteners ➔ **short cooling times**

Cooling curve comparison
Küba high performance SG Air Coolers

Without Küba Air Straighteners

- Poor room ventilation
- Large differences in product temperatures: 6K
- Relatively long cooling times

With Küba Air Straighteners

- Better distribution of cooled air
- Products are cooled more evenly: 1K
- Short cooling times
- Lower temperature difference (DT1)
- Lower operational costs

Key:

- t_0 = Evaporating temperature at coil outlet
- t_{oh} = Superheated temperature at coil outlet
- t_{L1} = Air entry temperature into the air cooler

Küba Air Straighteners ➔ **More uniform product temperatures**

Uniform product temperatures:
Documented by measurement series in cold storage area

To perform the cooling curve comparison, a cold storage area was filled with stacks of goods. The measuring points 1-11 show the development of the product core temperature in relation to cooling time.

The starting conditions were identical in both trials – entry temperature 24 °C. For the cooler without an Air straightener, the temperature difference in the stack of goods after 21 hours cooling time was 6K.

The Küba SG with Air straightener achieved the outstanding result of only a 1K temperature difference.

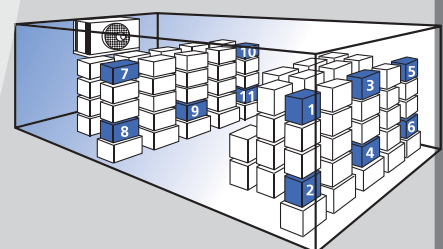
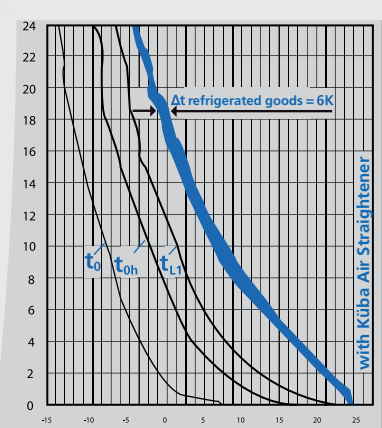
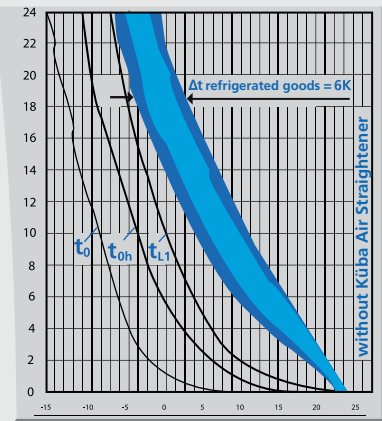
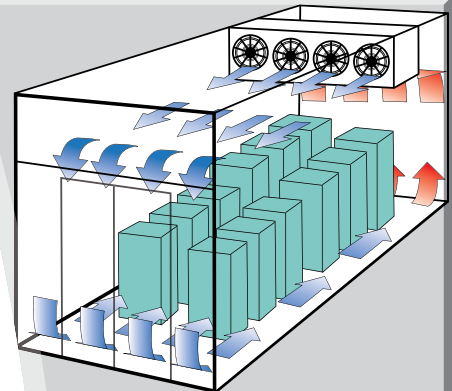



Construction

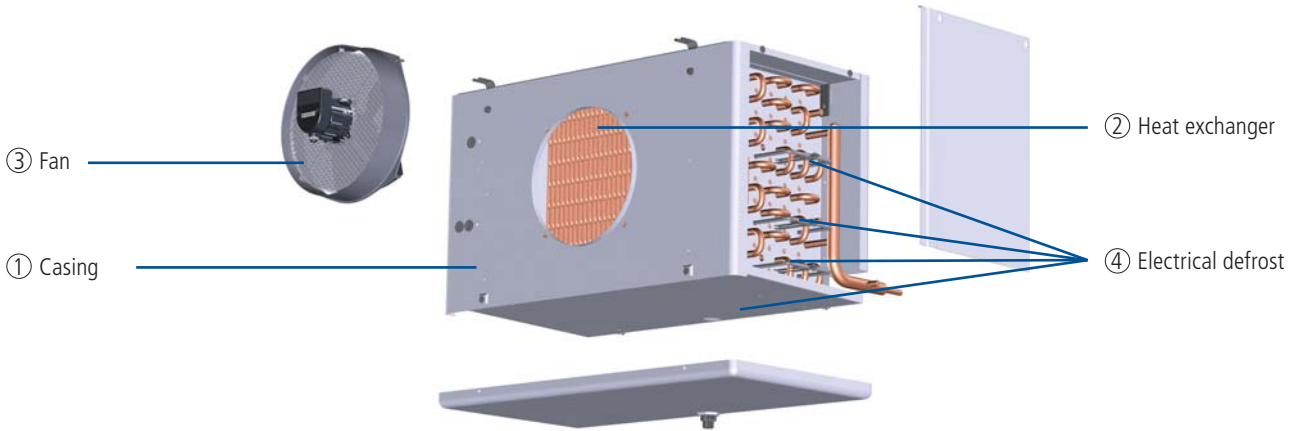

1. Casing

- Al-Stucco
- High-grade powder coating, papyrus white RAL 9018
 - Food quality
 - Easy to clean
 - Optimum corrosion protection
- Drip tray and side panels removable
- Stainless steel mounting material and brackets
- Plastic drain

2. Heat exchanger

- Fin spacing
 - SGA.C: 4,5mm
 - SGB.C: 7mm
 - SGL.C: 12mm
- Tube arrangement aligned, spacing 50 x 50 mm
- HFE® tube / fin system
- Tubing: Cu-special
- Fins: Al
- End plates: Al
- Küba-CAL® refrigerant distributor for multiple injection

3. Fans

- Ø250 to 500 mm
- In accordance with VDE specifications with built-in protector
- Application range: -40 °C bis +45 °C
- SG. 011 -083C: 230 ±10%V-1~, 50/60Hz
- SG.091 -103C: 400±10%V-3~, 50/60Hz
- Protection class IP44 in accordance with EN 60529
- Insulation class F in accordance with EN 60034
- Operating data can be found with Küba Select or in the technical data

• Optional Controller:	011-083	091-103
Phase control	<input checked="" type="checkbox"/>	<input checked="" type="checkbox"/>
Transformer	<input checked="" type="checkbox"/>	<input checked="" type="checkbox"/>
Delta / star	<input type="checkbox"/>	<input type="checkbox"/>
Frequency converter	<input type="checkbox"/>	<input checked="" type="checkbox"/>

⚠ Please observe the manufacturer's information.

Motor label data (max. allowable value +40°C)

	50 Hz			60 Hz		
	min ⁻¹	W	A	min ⁻¹	W	A
SG.011/021C	1300	38	0,17	1500	52	0,21
SG.031/041C	1300	90	0,40	1415	128	0,51
SG.051-081C	1360	210	0,95	1395	148	0,58
SG.091/101C	1400	450	1,00	1600	630	1,2



Note:
4 and 4 motor models on request

4. Electrical defrost

- 230 ±10% V-1~ or 400 ±10% V-3~ -Y
- Heaters with CrNi steel sleeve
- Vapour-tight connections
- Connector cable 1.5 mm² x 1000 mm
- Designed to defrost the fin package quickly and evenly
- To prevent vapour build-up and to accomplish heat transfer with almost no loss, the heaters are mounted in special expanded tube sleeves
- Wired ready for connection to the connection box in accordance with VDE specifications



Refrigerant / coolant

- Can be used with all HFC refrigerants, performance data can be found with Küba Select (Product Selection Software)
- For water / brine circulation choose your air cooler with Küba Select
- For CO₂ operation and for NH₃ applications immediate selection with Küba Select is possible; or ask our technical staff in sales



The performance data in the Q_v charts refer to the combination of materials: tubes, Cu / fins, Al.

Küba Blue Line
Freshness that lasts longer



Technical data (R404A)

SGA...C



Nomenclature

Standard

SG A E 10 2 C

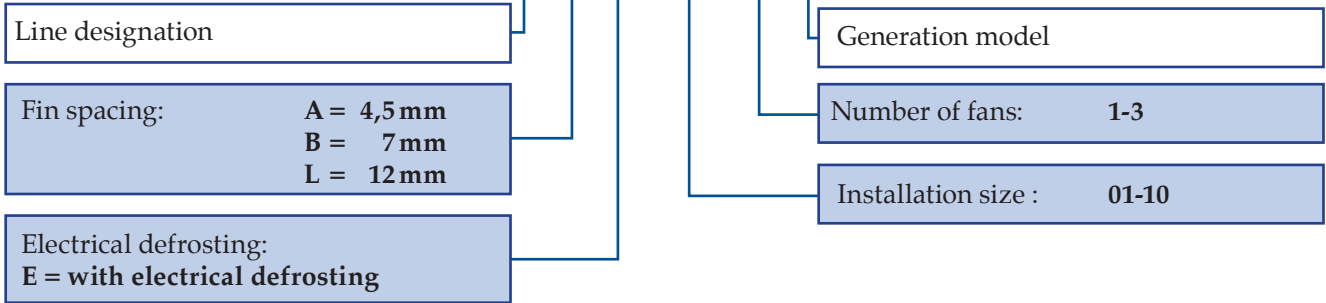

Model	Rating Q ₀ at 50 Hz		Surface m ²	Air flow m ³ /h	Air throw m	Tube volume dm ³	Connections			Fans (operating values at 50 Hz)				
	t ₁₁ ±0 °C DT1 = 8K	t ₁₁ -18 °C DT1 = 7K					Inlet Ø mm	Outlet Ø mm	Blade Ø mm	Type of current	min ⁻¹	W	A	
	kW	kW					Ø mm	Ø mm	Ø mm					
SGA 011C	⊕	1,00	0,79	7,3	620	7	1,3	10	15	250		1301	32	0,15
SGA 021C	⊕	1,23	0,97	9,7	520	7	1,3	10	15	250		1301	32	0,15
SGA 031C	⊕	1,98	1,57	12,5	1060	10	2,1	10	15	300	230±10%	1295	86	0,38
SGA 041C	⊕	2,19	1,73	16,6	970	10	2,8	10	15	300	V-1~	1295	86	0,38
SGA 051C	⊕	3,45	2,74	23,1	1620	13	3,8	10	22	400	50/60 Hz	1307	105	0,46
SGA 061C	⊕	3,81	3,03	28,7	1600	13	4,8	10	22	400		1307	105	0,46
SGA 071C	⊕	5,69	4,52	34,5	2610	19	5,7	10*	22	400		1362	205	0,90
SGA 081C	⊕	6,73	5,34	51,5	2640	19	8,8	10*	28	400	230/400	1362	205	0,90
SGA 091C	⊕	9,42	7,49	61,8	4010	23	10,6	10*	28	500	±10%V-3~	1417	360	0,86
SGA 101C	⊕	10,80	8,57	82,3	4300	23	13,6	12*	35	500	50/60 Hz	1417	360	0,86
SGA 012C	⊕⊕	1,99	1,57	14,5	1240	11	2,3	10	15	250		1301	32	0,15
SGA 022C	⊕⊕	2,45	1,94	19,2	1040	11	3,1	10	18	250		1301	32	0,15
SGA 032C	⊕⊕	3,96	3,14	24,6	2120	14	3,9	10	18	300	230±10%	1295	86	0,38
SGA 042C	⊕⊕	4,38	3,47	33,0	1940	14	5,3	10	22	300	V-1~	1295	86	0,38
SGA 052C	⊕⊕	6,91	5,48	45,7	3240	18	7,6	10*	28	400	50/60 Hz	1307	105	0,46
SGA 062C	⊕⊕	7,62	6,05	57,1	3200	18	9,1	12*	28	400		1307	105	0,46
SGA 072C	⊕⊕	11,37	9,02	68,5	5220	26	10,8	12*	35	400		1362	205	0,90
SGA 082C	⊕⊕	13,46	10,68	103,0	5280	26	16,6	15*	35	400	230/400	1362	205	0,90
SGA 092C	⊕⊕	18,86	14,98	123,0	8020	33	19,8	15*	35	500	±10%V-3~	1417	360	0,86
SGA 102C	⊕⊕	21,60	17,16	164,0	8600	33	26,1	15*	42	500	50/60 Hz	1417	360	0,86
SGA 013C	⊕⊕⊕	2,99	2,36	21,5	1860	13	3,4	10	15	250		1301	32	0,15
SGA 023C	⊕⊕⊕	3,68	2,92	28,7	1560	13	4,5	10	22	250		1301	32	0,15
SGA 033C	⊕⊕⊕	5,94	4,70	37,0	3180	17	5,8	10	28	300	230±10%	1295	86	0,38
SGA 043C	⊕⊕⊕	6,57	5,20	49,2	2910	17	8,1	10*	28	300	V-1~	1295	86	0,38
SGA 053C	⊕⊕⊕	10,35	8,21	68,3	4860	22	11,1	12*	35	400	50/60 Hz	1307	105	0,46
SGA 063C	⊕⊕⊕	11,42	9,07	85,5	4800	22	13,1	12*	35	400		1307	105	0,46
SGA 073C	⊕⊕⊕	17,06	13,54	103,0	7830	32	16,2	15*	35	400		1362	205	0,90
SGA 083C	⊕⊕⊕	20,19	16,02	154,0	7920	32	24,6	22*	42	400	230/400	1362	205	0,90
SGA 093C	⊕⊕⊕	28,29	22,47	184,0	12000	40	29,6	22*	54	500	±10%V-3~	1417	360	0,86
SGA 103C	⊕⊕⊕	32,41	25,75	246,0	12900	40	38,5	22*	54	500	50/60 Hz	1417	360	0,86

* Multiple injection with direct expansion using Küba CAL® distributors. The cooler rating at 60 Hz is 10% higher on average due to the higher speed and higher air flow.



Q_v chart (EN328, R404A) SGA...C 4,5 mm

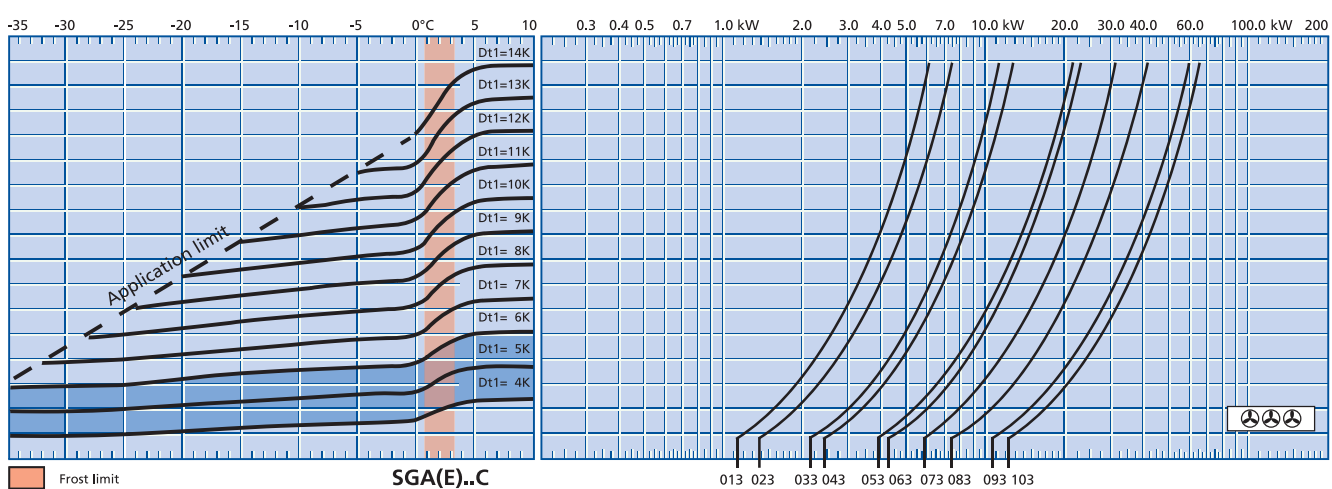
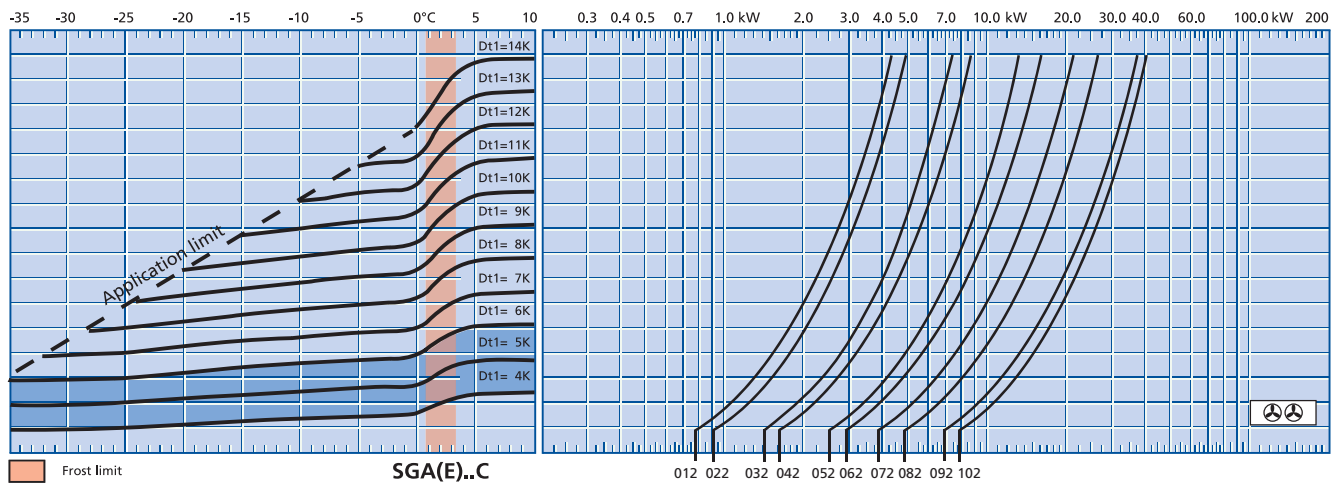
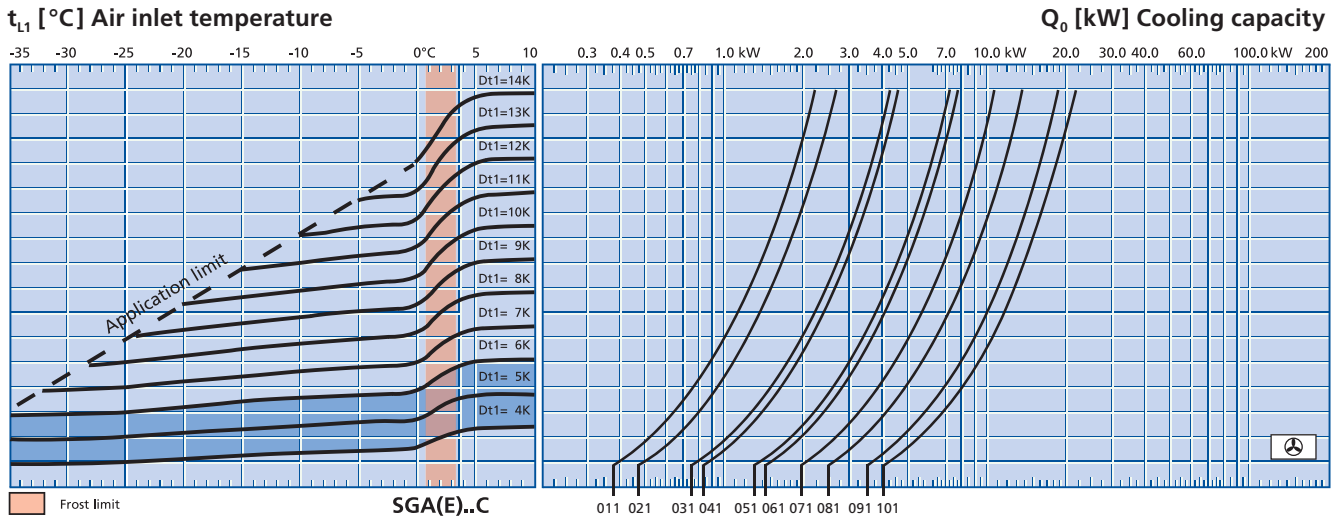

Q₀ = Cooling capacity
 t_{L1} = Air inlet temperature
 t₀ [°C] = Evaporating temperature (coil outlet)
 DT1 [K] = Temperature difference = t_{L1} - t₀ (°C)

DT1 = 4 K bis 6 K
 with electronic expansion valve

Example selection:
 For example and explanation, see the information section on p. 136.



Dimensional drawings

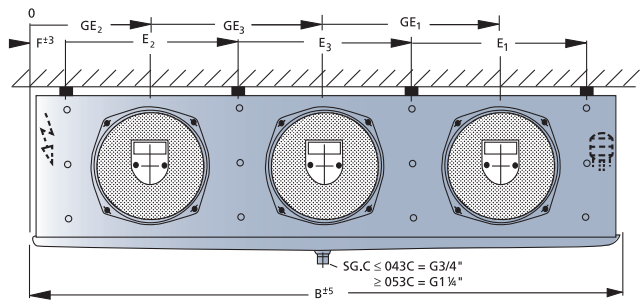
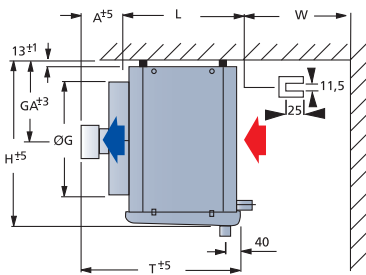
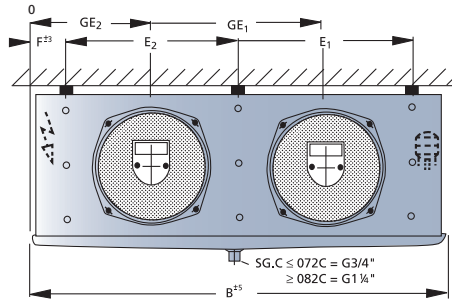
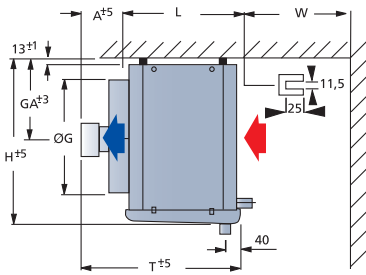
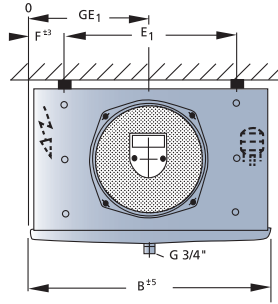
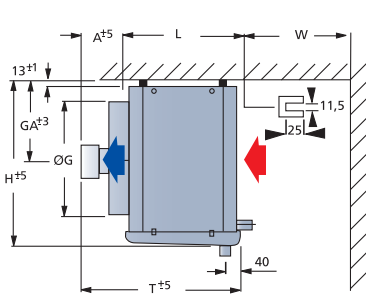

54



With double, insulated drip trays the following dimensions are changed:

- Width B:** +60mm
- Height H:** +30mm
- Depth T:** +30mm

Sound power level L_{WA} [dB(A)]



Größe	SGA/SGB/SGL		
	⊕	⊕ ⊕	⊕ ⊕ ⊕
01	59	62	64
02	59	62	64
03	66	69	71
04	66	69	71
05	70	73	75
06	70	73	75
07	75	78	80
08	75	78	80
09	78	81	83
10	78	81	83



Dimensional drawings, electric defrosting, weights

Size	Dimensions [mm]																Electrical Defrosting			Net weight		
	H	B	T	L	E ₁	E ₂	E ₃	F	A	W	W Hood	ØG	GA	GE ₁	GE ₂	GE ₃	Coil	Tray	Total	SGA	SGB	SGL
	mm	mm	mm	mm	mm	mm	mm	mm	mm	mm	mm	mm	mm	mm	mm	mm	mm	kW	kW	kW	kg	kg
011C	360	565	420	345	380	-	-	93	80	200	290	265	160	283	-	-	0,77	0,35	1,16	12	11	-
021C	360	565	420	345	380	-	-	93	80	200	290	265	160	283	-	-	0,77	0,35	1,16	13	12	-
031C	460	665	440	345	480	-	-	93	100	200	340	321	210	333	-	-	0,96	0,42	1,38	18	17	-
041C	460	665	440	345	480	-	-	93	100	200	340	321	210	333	-	-	0,96	0,42	1,38	20	19	-
051C	560	815	570	415	530	-	-	143	160	300	430	419	260	408	-	-	1,44	0,24	1,68	30	29	28
061C	560	815	570	415	530	-	-	143	160	300	430	419	260	408	-	-	1,61	0,24	1,85	33	32	30
071C	560	915	640	495	630	-	-	143	150	300	430	419	260	458	-	-	1,73	0,29	2,02	41	39	37
081C	560	1065	640	495	780	-	-	143	150	300	430	419	260	533	-	-	2,18	0,35	2,53	53	51	49
091C	660	1065	650	495	780	-	-	143	160	400	500	525	320	533	-	-	2,90	0,35	3,25	62	59	56
101C	660	1315	650	495	1030	-	-	143	160	400	500	525	320	658	-	-	3,68	0,44	4,12	71	68	65
012C	360	1015	420	345	730	365	-	143	80	200	290	265	160	690	325	-	1,38	0,69	2,07	23	21	19
022C	360	1015	420	345	730	365	-	143	80	200	290	265	160	690	325	-	1,38	0,69	2,07	24	22	20
032C	460	1215	440	345	930	465	-	143	100	200	340	321	210	840	375	-	1,72	0,77	2,49	35	33	31
042C	460	1215	440	345	930	465	-	143	100	200	340	321	210	840	375	-	1,72	0,77	2,49	39	37	35
052C	560	1375	570	415	1030	515	-	173	160	300	430	419	260	945	430	-	2,64	0,44	3,08	58	55	53
062C	560	1375	570	415	1030	515	-	173	160	300	430	419	260	945	430	-	2,64	0,44	3,08	64	61	58
072C	560	1575	640	495	1230	615	-	173	150	300	430	419	260	1095	480	-	3,11	0,52	3,63	80	76	72
082C	560	1875	640	495	1530	765	-	173	150	300	430	419	260	1320	555	-	3,90	0,65	4,55	104	100	96
092C	660	1875	650	495	1530	765	-	173	160	400	500	525	320	1320	555	-	6,50	0,65	7,15	120	114	108
102C	660	2375	650	495	2030	1015	-	173	160	400	500	525	320	1695	680	-	8,42	0,84	9,27	137	130	123
013C	360	1365	420	345	1080	365	715	143	80	200	290	265	160	1040	325	683	1,84	0,92	2,76	34	31	28
023C	360	1365	420	345	1080	365	715	143	80	200	290	265	160	1040	325	683	1,84	0,92	2,76	37	34	31
033C	460	1665	440	345	1380	465	915	143	100	200	340	321	210	1290	375	833	2,42	1,21	3,63	51	48	45
043C	460	1665	440	345	1380	465	915	143	100	200	340	321	210	1290	375	833	2,42	1,21	3,63	57	54	51
053C	560	1875	570	415	1530	515	1015	173	160	300	430	419	260	1445	430	938	3,90	0,65	4,55	86	81	76
063C	560	1875	570	415	1530	515	1015	173	160	300	430	419	260	1445	430	938	3,90	0,65	4,55	95	90	85
073C	560	2175	640	495	1830	615	1215	173	150	300	430	419	260	1695	480	1088	4,47	0,75	5,22	118	111	104
083C	560	2625	640	495	2280	765	1515	173	150	300	430	419	260	2070	555	1313	5,63	0,94	6,57	154	147	140
093C	660	2625	650	495	2280	765	1515	173	160	400	500	525	320	2070	555	1313	9,37	0,94	10,32	180	170	160
103C	660	3375	650	495	3030	1015	2015	173	160	400	500	525	320	2695	680	1688	12,09	1,82	13,92	240	228	216



The dimensions are only valid for standard model design!
Note the differences in dimension for versions and accessories.



Accessories

Air hoses (on site procurement, not available from Küba)

Ventilation can be optimised with textile / PVC air hoses.

Applications

- Applications in work and production areas
- Cooled goods that are sensitive to drafts (e.g. flowers, ripening cheeses)

Advantages

The air hoses make uniform air distribution possible at very low air speeds.

- Working in a draft-free environment yields low illness rates
- Maximum protection for sensitive cooled goods
- No condensation water: temperatures do not fall below the dew point because air can penetrate the woven material

Calculation hint

Please order the corresponding adapter (see page 58). Please take the respective pressure drop for the cooler rating into consideration.

